

The GO® Proximity Principle

Single-magnet 80 Series GO® Switches are designed for use with two independent circuits. A ferrous armature is positioned off-center, creating dominance and placing the contacts for both circuits in a Normally Closed (N/C) position (Figure 1).

When a ferrous actuator enters the sensing area of the switch (Figure 2), it deflects magnetic flux from the N/C side of the armature and the Normally Open (N/O) side becomes dominant. The armature then snaps to its alternate position, closing the N/O contacts. When the actuator is removed, the magnet again becomes dominant on the N/C side and the armature returns to its N/C position.

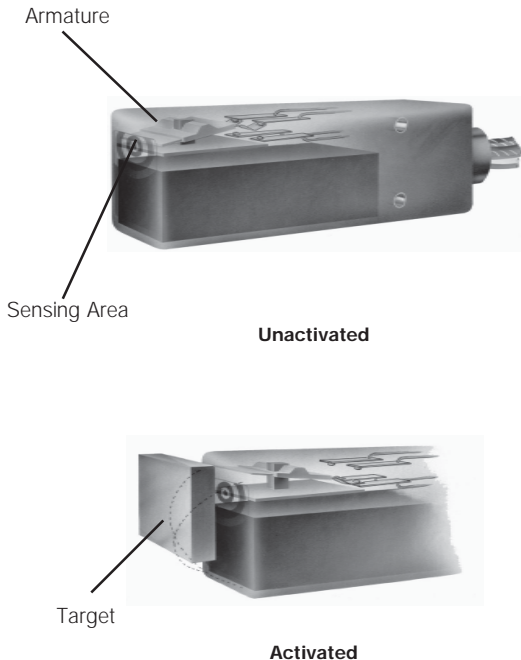

SPECIFICATIONS - DPDT

- Contacts:** Double Pole, Double Throw, 2 Form C., Silver cadmium oxide, gold flashed
- Rating:** 1250 watts @ 120, 240, 480 or 600 VAC. Maximum cycle rate of 10 cycles per minute resistive load at 10 amps.
- Housing:** Environmentally sealed brass or stainless steel
- Conduit Outlet:** 1/2" -14NPT
- Repeatability:** 0.002" (0.05mm) typical
- Sensing Distance:** Approx. 1/4" (7mm) end sensing. (NOTE: Sensing distance may be affected by surrounding ferrous materials and actuator size)
- Differential:** Approx. 1/4" (72mm)
- Response time:** 8 milliseconds
- Temperature Rating:** -40°F. (-40°C) to 221° F (105° C)

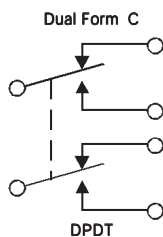

Mounting

- Determine the desired operating point.
- Locate switch and/or actuator to assure that actuator comes well within switch's sensing area.
- Use a ferrous actuator of sufficient size.
- Use external magnets, available from the factory, to extend the sensing distance.
- Avoid contact between switch and actuator, which may damage switch.
- Switches may be mounted in any position.
- For best results, mount switch on non-ferrous materials.
- Steel placed outside the switch's differential area will not affect functionality.
- Switches may be mounted on ferrous metals when necessary, though this is not recommended. Sensing distance will be reduced. Check with factory.
- Switch must be centered on ferrous mounting bracket so that effects on the magnet are uniform.

Attachment of Conduit or Cable

- Attach conduit or cable correctly.
 - When using long runs of conduit or cable, place supports close to the switch to avoid pulling switch out of position.
 - If switch is mounted on a moving part, be sure flexible conduit is long enough to allow for movement, and positioned to eliminate binding or pulling.
 - For installation in hazardous locations, adhere to local electrical codes.
 - All conduit connected electrical devices, including GO® Switches must be sealed against water ingress through the conduit system. The use of RTV moisture barriers in the conduit hub, wiring terminations and conduit junction provide a suitable solution. Drip loops with provision for accumulated water to escape prior to the connection to the switch should also be effective.

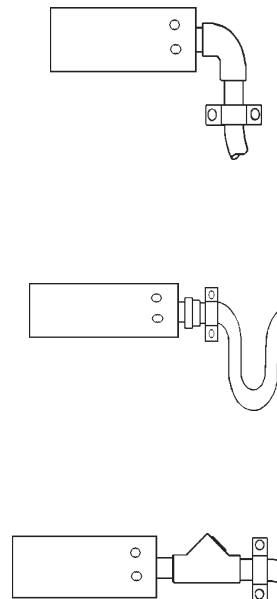

Standard GO® Switch Actuators

The part to be sensed can approach or pass across the sensing area from any direction. This permits unlimited over-travel and a wide variety of operating conditions. **CAUTION:** To assure optimum switch operation, the actuator speed should exceed 2 FPS (feet per second).

Switch Sensing

The standard actuator for the 80 Series is 1/2" x 1" x 4" steel bar with the 1/2" x 1/4" face pointing at the end of the switch. Sensing distance for this series is approximately 5/16". Always mount switch / actuator well within sensing distance. **NOTE:** Actuator size effects sensing distance.

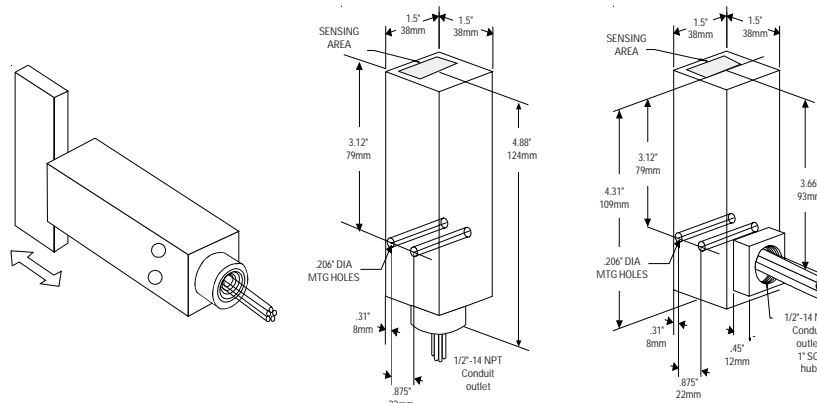

MANUFACTURER'S WARRANTY

TopWorx, Inc., warrants that each item of new equipment manufactured by it will be free from defects in material and workmanship under normal use and service; its obligation under this Warranty, being limited to making good, at its factory, and part of parts thereof, which shall be returned to it with transportation charges prepaid, within one year after the date of the purchase of such equipment by the original purchaser, and which its examination shall disclose to its satisfaction to have been thus defective. TopWorx, Inc., however, assumes no risk or liability for results of the use of the products purchased from it.

THIS WARRANTY IS IN LIEU OF ALL OTHER WARRANTIES, WHETHER OF MERCHANTABILITY FITNESS, OR OTHERWISE EXPRESSED OR IMPLIED, AND ALL OTHER OBLIGATIONS OR LIABILITIES AND GENERAL EQUIPMENT AND MANUFACTURING COMPANY, INC., NEITHER ASSUMES, NOR AUTHORIZES ANY PERSON TO ASSUME FOR IT ANY OTHER LIABILITY IN CONNECTION WITH THE SALE OF THIS EQUIPMENT.

No claims for labor in replacing defective parts and equipment and consequential damages will be allowed by the Company.

This Warranty shall not apply to equipment which has been subjected to misuse, negligence or accident.

This Warranty shall not apply to any equipment which shall have been repaired or altered, outside the Company's factory so as to affect such equipment's stability or reliability in the judgement of the Company.

TOPWORX

Advancing Valve Performance

3300 Fern Valley Road
Louisville, KY 40213 USA
www.topworx.com

(502) 969-8000 Tel
(502) 969-5911 Fax
info@topworx.com E-mail

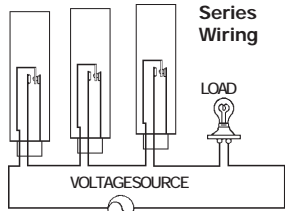

Series Wiring

Any number of GO® Switches may be wired in series, without voltage drop. By contrast, solid state switches have about two volts drop across each switch when operated. With a system of 12 volts and four switches in series, 8 volts are dropped across the switches. Only 4 volts are left to operate the load. When using GO® Switches, 12 volts are still available to operate the load.

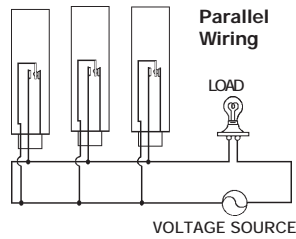

Parallel Wiring

When solid state switches are placed in parallel, there is about 100 microamps leakage through each switch. If ten switches were wired in parallel, the total leakage current would be 1000 microamps or one milliamps - sufficient current to indicate an "ON" condition to a programmable logic controller (PLC). **Any number of GO® Switches may be wired in parallel, with no current leakage and without drawing operating current.**

Contact chamber completely potted and sealed from the environment



Rugged Brass or Stainless Steel housing

Multiple termination options: Lead wires, Cable, Quick Disconnects

GO® Switch Hook-up Diagrams

Form "C" Typ. Dual Load Hook-up

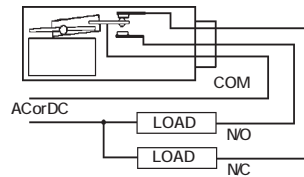

Form "B" Normally Closed Typ. Overtravel or Limits, Hook-up

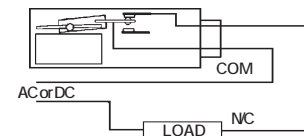

Form "A" Normally Open Typ. Alarm or Limits Warning Hook-up

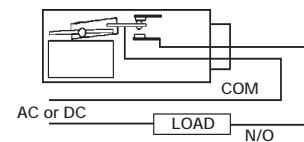

All GO® Switches are "pure" contact switches, meaning that they have no voltage drop when closed, nor do they have any leakage current when open. For multi-unit installation, switches may be wired in series or parallel, as shown.

NOTE: Occasionally the 80 Series DPDT is used for its end sensing, when only a SPDT switch is required. If this is the case in your application it is to your best advantage to parallel the lead wires (red to red/white stripe, blue to blue/white stripe and black to black/white stripe, essentially converting a DPDT switch to a SPDT configuration) so that both individual circuits see the same load and therefore wear equally to give long contact life and the reliable service you expect with GO® Switch.

Wiring Diagrams

SPDT, FORM C

4 Wire PVC & HiTemp Leads	
N/C	Red
N/O	Blue
COM	Black
GND	Green

Terminations A & F

SPDT, FORM C

Mini-Change QDC - 3 Pin	
Pin 1	COM (Green)
Pin 2	N/C (Black)
Pin 3	N/O (White)

Termination DCA

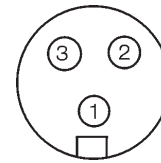

SPDT, FORM C

Mini-Change QDC - 5 Pin	
Pin 1	N/O (White)
Pin 2	N/C (Red)
Pin 3	GND (Green)
Pin 4	Inactive (Orange)
Pin 5	COM (Black)

Termination DCG

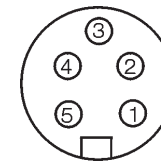

SubSea - 3 Pin - Right Angle

Pin 1	COM (Black)
Pin 2	N/O (White)
Pin 3	N/C (Green)

Termination 3DE

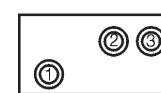

SPDT, FORM C

SO Cable	
N/C	Red
N/O	White
COM	Black
GND	Green

Termination B

SPDT, FORM C

Mini-Change QDC - 4 Pin	
Pin 1	COM (Black)
Pin 2	N/O (White)
Pin 3	N/C (Red)
Pin 4	GND (Green)

Termination DCD

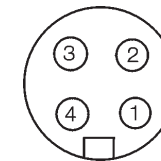

SPDT, FORM C

SubSea - 3 Pin - Lock Sleeve	
Pin 1	N/C (Black)
Pin 2	COM (White)
Pin 3	N/O (Green)

Termination 3DD

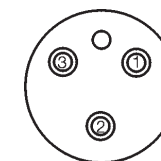

SubSea - 8 Pin - Lock Sleeve

Pin 1	COM ₁ (Black)
Pin 2	N/O ₁ - (White)
Pin 3	N/C ₁ - (Red)
Pin 4	GND ₁ - (Green)
Pin 5	N/C ₂ - (Orange)
Pin 6	N/O ₂ - (Blue)
Pin 7	COM ₂ - (White/Black)
Pin 8	Inactive (Red/Black)

DPDT, TWO FORM C

PVC Leads, Cable & Hi-Temp Teflon Leads	
N/C1 - Red	N/C2 - Red/White Stripe
N/O1 - Blue	N/O2 - Blue/White Stripe
COM1 - Black	COM2 - Black/White Stripe
GND - Green	

Termination A & F

DPDT, TWO FORM C

Mini-Change QDC - 7 Pin	
Pin 1	N/O 2 - Black/White
Pin 2	COM 1 - Black
Pin 3	N/C 2 - White
Pin 4	N/C 1 - Red
Pin 5	COM 2 - Orange
Pin 6	N/O 1 - Blue
Pin 7	GND - Green

Termination DCH

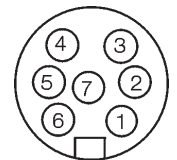

SPDT, FORM C

SubSea - 4 Pin - Lock Sleeve	
Pin 1	COM (Black)
Pin 2	N/O (White)
Pin 3	N/C (Red)
Pin 4	GND (Green)

Termination 4DD

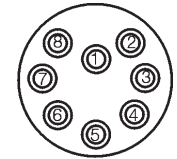
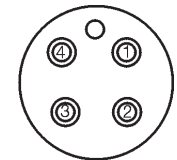

Termination 8DD